

Information for Incoming Companies



The Stables Theatre
Stockwell Lane
Wavendon
Milton Keynes
MK17 8LU

For further information please contact The Stables Technical Department
on 01908 280822 or email technical@stables.org

General

- The Stables is an internationally renowned music organisation with a vision to engage the widest range of people with music in all its diversity. It delivers its vision through its concert and event programme at The Stables Theatre in Wavendon, Milton Keynes. It also runs an extensive learning and participation programme in the venue and across the local area and produces a range of work in other spaces including the biennial IF: Milton Keynes International Festival.

History

- The world-renowned jazz musicians Sir John Dankworth and Dame Cleo Laine founded The Stables in 1970 in some outbuildings at their home as a venue for concerts and education activities. In October 2000, the new Stables Theatre opened its doors, with a second phase of development opening in 2007. It is now home to The Jim Marshall Auditorium with 398 and Stage 2 (80 seated or 120 standing) and presents around 400 concerts and 250 education sessions each year.

Directions

- **From M1 Junction 14**

Head towards Milton Keynes; At the first roundabout turn left onto the A5130

At the Kingston roundabout take the second exit signposted Wavendon/Woburn Sands, onto the A5130 (Newport Road)

Take the second right by the traffic lights onto the new access road, Dankworth Way

- **From M1 Junction 13**

Head towards Milton Keynes on A421

At the Kingston roundabout take the first exit signposted Wavendon/Woburn Sands, onto the A5130 (Newport Road)

Take the second right by the traffic lights onto the new road, Dankworth Way

- **From anywhere**

Head towards Milton Keynes - Aim for the junction of the A421 (H9 Groveway) and the A5130 at the Kingston roundabout - Take the turn signposted Wavendon –

Take the second right by the traffic lights onto the new access road, Dankworth Way

**For further information please contact The Stables Technical Department
on 01908 280822 or email technical@stables.org**

Jim Marshall Auditorium

Get In

- The main stage has a load in door of 2.7m wide by 3.9m high at stage level (.75m from road level) with direct access to stage left.
- It can be found as you enter The Stables site and drive to the left and the green load in door can be seen on your right.

Parking

- Vehicles may be left in the loading bay or adjacent staff car park

Access

- The Stables is highly accessible to artists with limited mobility
- Parking bays for blue badge holders are available directly outside the main entrance on a first come first served basis and there is one bay in the staff car park
- There is level step-free access from the staff car park to the backstage area, green room, dressing rooms and auditorium
- There is a stage lift for wheelchair users to access the stage area from stage left
- There is a passenger lift from the auditorium to the foyer area
- There is one gender neutral disabled toilet facility situated in the backstage area
- The Jim Marshall Auditorium is fitted with an Ampetronic loop system
- Assistance dogs are welcome in the venue

Food & Catering

- The Stables is situated in a rural setting and food outlets are within a few minutes' drive away.
- We do not have an in-house kitchen for touring companies to use; we do have a microwave and kettle for use in the green room.

Wardrobe

- Washer, dryer and ironing facilities are available to use at no charge.

**For further information please contact The Stables Technical Department
on 01908 280822 or email technical@stables.org**

Smoking

- There is a strict no smoking policy in place in the whole venue.

Mobile Phones

- Most mobile phone networks work in the theatre.

Security

- The stage door is not manned.

Fire

- There is a full fire alarm system in place, with detectors in every room. During the show the detectors over stage can be disabled, allowing the use of most forms of smoke and haze. Companies are asked to seek advice from the duty manager re: the use of any electrical equipment, if the fire alarm is activated, please leave the building via the fire exit signs

Evacuation Point

- If the theatre is evacuated for any particular reason, then the backstage evacuation point is the Stables staff car park.

First Aid

- A first Aid Box can be found behind the snack bar in the foyer and in the stage left lobby. The duty manager is the first aider on site.

**For further information please contact The Stables Technical Department
on 01908 280822 or email technical@stables.org**

Technical Information

Auditorium Capacity

- 398 (including 8 disabled allocations)
- Seats are positioned 244 straight on, 144 on the two side blocks.

Stage

- The stage is of a wooden construction, with original style laminate boards. The main stage and the forestage are flat.
- Movable acoustic diffuser wall positioned upstage, which can be moved further downstage as required.

Flying

- 4 hemp bars UDL 120kgs, 4 winch bars UDL 330kgs
NO ACCESS ABOVE GRID
- Measured from front of proscenium arch

Hemp	1	.7m	Front Black Border
Winch	1	.95m	Empty Bar
Hemp	2	1.5m	Empty Bar
Winch	2	1.85m	Venue Fixtures
Hemp	3	2.3m	Black Border
Winch	3	2.8m	Venue Fixtures
Hemp	4	3.35m	Empty Bar
Winch	4	3.65m	Empty Bar

Dressing Rooms

- 4 x 4 person rooms – stage left can be joined to make 2 rooms both with en suite shower
- 1 x Green room – stage left with fridge, kettle, microwave and comfortable seating. Can be changed into dressing room.
- 1 x rehearsal room – stage right 7m/23ft x 5m/16.5ft. Can be used as dressing room.
- Wi-Fi available free of charge - contact the duty manager for password

**For further information please contact The Stables Technical Department
on 01908 280822 or email technical@stables.org**

Sound

- FOH Console: Yamaha CL5
- Stage Boxes: 2 x Yamaha RIO 3244-D: 1 unit at S/L, 1 unit at S/R
- **PA System: Professionally calibrated January 2024 to provide consistent coverage in the space.**
NB: System control software is not available for visiting production use at FOH.

Left/Right flown line array: (per side)

1 x L-Acoustics ARC FOCUS
2 x L-Acoustics ARC WIDE

Left/Right Flown Side Fills: (per side)

2 x L-Acoustics A10 WIDE

Sub Bass:

3 x L-Acoustic SB18 Subs (per side) in Cardioid Configuration (mono output)

- Monitor Wedges:
8 x L-Acoustics X12 speakers on 8 separate channels
1 x Martin Audio Backline S18 (Drum Fill Sub)

Please note that touring PA cannot be flown. We can only ground stack Left and Right on the stage.

Data tie lines available stage left and right for connecting visiting production consoles to FOH position.

Three feeds (Left/Right and Sub bass) to connect visiting production consoles to the PA system.

Monitor system (hire charge applicable)

- Console: Yamaha CL5

Monitor System needs to be requested specifically, and cost agreed prior to arrival.

Stage power

- **U/S/L (All single Phase is on Sound Phase)**
2 x 63A 3ph Ceeform. 1 x 32A single Ceeform. 2 x 16A single Ceeform
- **Various points around stage**
13A ring mains
Non-Dimmable 15A - controllable from LX desk position

**For further information please contact The Stables Technical Department
on 01908 280822 or email technical@stables.org**

Microphones

- 23 x Shure SM 58, 5 x Shure SM 57, 15 x Shure Beta SM 58, 14 x Shure Beta SM 57, 3 x Shure Beta 98
- 6 x Shure Beta 87A, 2 x Shure Beta 91, 6 x Sennheiser 602, 10 x Sennheiser 604, 7 x Sennheiser 609
- 3 x Sennheiser 664, 8 x Sennheiser 421, 3 x Beyerdynamic M88, 1 x Hebden Sound CM1050
- 4 x Sennheiser K6-ME66, 2 x Audio-Technica 4040, 2 x Audio-Technica 4050, 3 x Audio-Technica 4041
- 2 x AKG C414B, 2 x AKG C414, 8 x SE7, 4 x Beyerdynamic 201TG, 2 x Audix D6
- 22 x BSS AR-133 Active DI Box

Wireless Microphone System (hire charge may be applicable):

Sennheiser ew300 G3 wireless system for use over 4 channels with a combination of:

- 4 x Sennheiser handheld microphone with MMD 945-1 capsule
- 4 x Sennheiser body pack
- 4 x lavalier microphone
- 2 x Pulse mic3200 headset
- 2 x t.bone HeadmiKe - O EW headset

The Stables has an OFCOM PMSE Fixed Site Licence for use with the following frequencies:

630.50000 MHz / 632.92500 MHz / 634.67500 MHz / 635.47500 MHz

Projection (hire charge may be applicable):

- 1 x Christie LHD700 7000 Lumens (Permanently hung for front projection)
- 1 x Stumpfl Monoblox32 16:9 front projection screen (488cm x 274cm)
- White cyclorama cloth covering upstage wall
- Source output requires HDMI connection to Atem Mini Extreme switcher
- SDI cabling and BlackMagic converters for routing from stage and FOH control to projector

**For further information please contact The Stables Technical Department
on 01908 280822 or email technical@stables.org**

Lighting

- Console: ETC Congo Junior
- All flown venue generic and non-generic fixtures are on universe 1
- House lights on DMX via universe 1
- Second free DMX universe available for visiting company LX packages via 5 pin stage patch
- Dimmers: 48 x 3kW, 6 x 5kW
- Movers: 8 x Martin Rush MH7 Hybrid and 3 x Martin Rush MH6 Wash
- LED Pars: 14 x Studio Due ParLed Pro, 4 x Lanta Aurora 12x12 HEX and 8 x Lanta RGB
- LED Uplighters: 6 x Chauvet Colorado 1 Quad
- Generic: 8 x 1kW ADB Profiles, 8 x 1kW Treatro Profiles, 4 x Silhouette 30 Profiles
- Lanterns: 8 x 1kW ADB Fresnels, 2 x 1kW Par 64 Parcans, 4 x 1kW Floor cans
- Follow spots: 2 x LDR Astro 250 PLUS LED
(Positioned House Left and House Right)

Additional

- 5 x TecPro Beltpacks and Headsets for comms
- Le Maître MVS hazer with DMX control
- Mirror ball
- Lectern
- Approx. 20 stage chairs
- Piano: Steinway B (hire charge may be applicable)
- Rostra: same surface as stage / pine coloured laminate, all 0.4m/1.25ft high, 8 x 1.8m/6ft x 0.9m/3ft, 3 x 0.6m/2ft x 1.8m/6ft
- 7 Section Drum Shield

**For further information please contact The Stables Technical Department
on 01908 280822 or email technical@stables.org**

Health & Safety

- All electrical plant equipment must comply with the current Electricity at Work Regulations 1998 and smaller equipment must comply with BS. 7909:1998
- All technical equipment must have secondary safety fittings.
- Specific Risk Assessments, Work Associated Procedures, PAT test paperwork stage and lighting plans must be submitted three weeks prior to the get in day.
- All fabrics used must conform to standard fire regulations BS. 5867 part 2, a fire-retardant certificate must be submitted for each material used.
- All rigging, flying and means of suspension must comply with the current LOLER Regulations 1998.
- Any regulation or areas you might be unsure about conforming, please call the Technical Department for clarification.

Special Effects

- Method statements and risk assessments must be sent through to the technical department (technical@stables.org) at least three weeks prior to your performance and you will be sent confirmation that the effects are allowed for use.

**For further information please contact The Stables Technical Department
on 01908 280822 or email technical@stables.org**

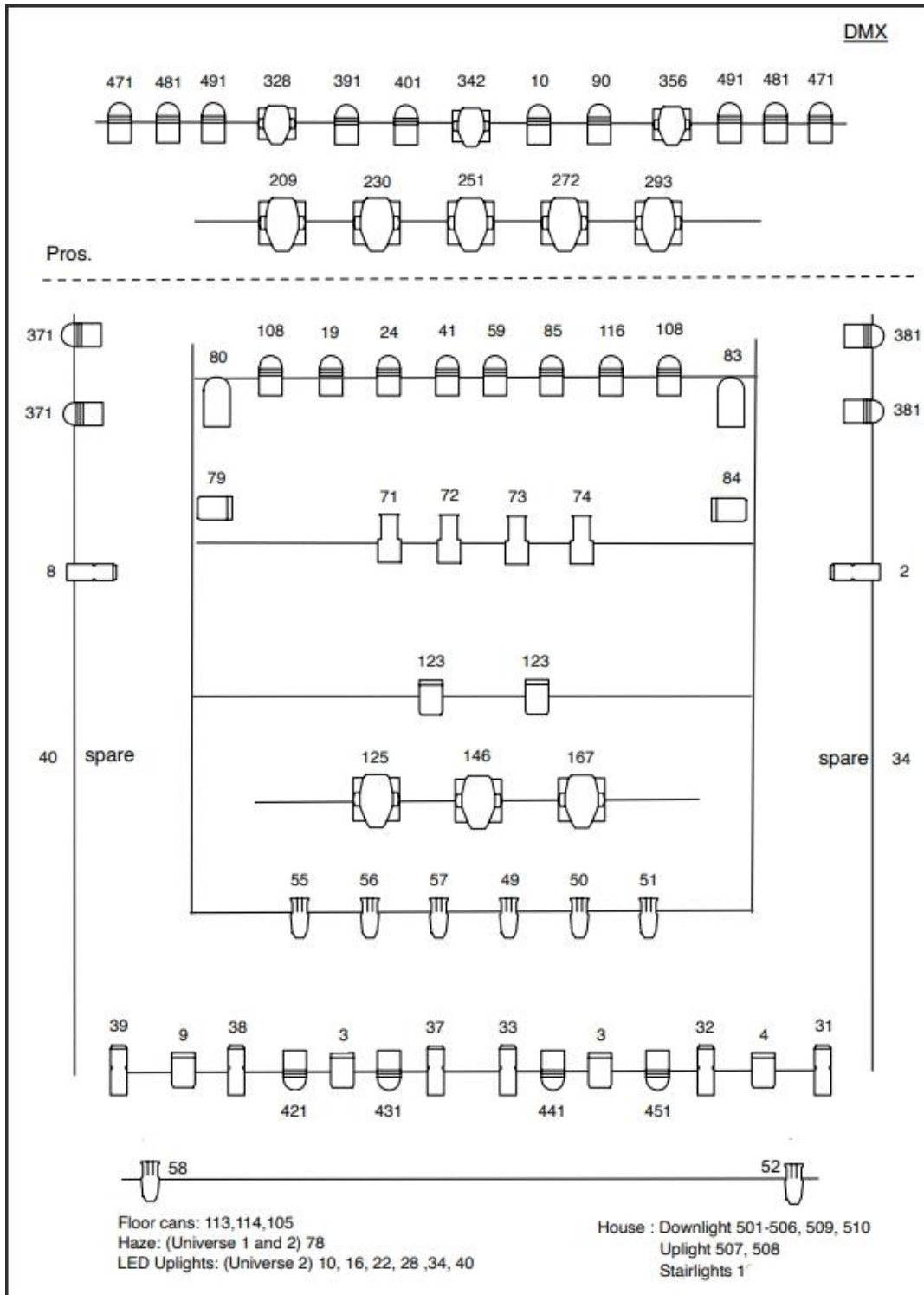

The Stables Theatre Lighting Plot

**For further information please contact The Stables Technical Department
 on 01908 280822 or email technical@stables.org**

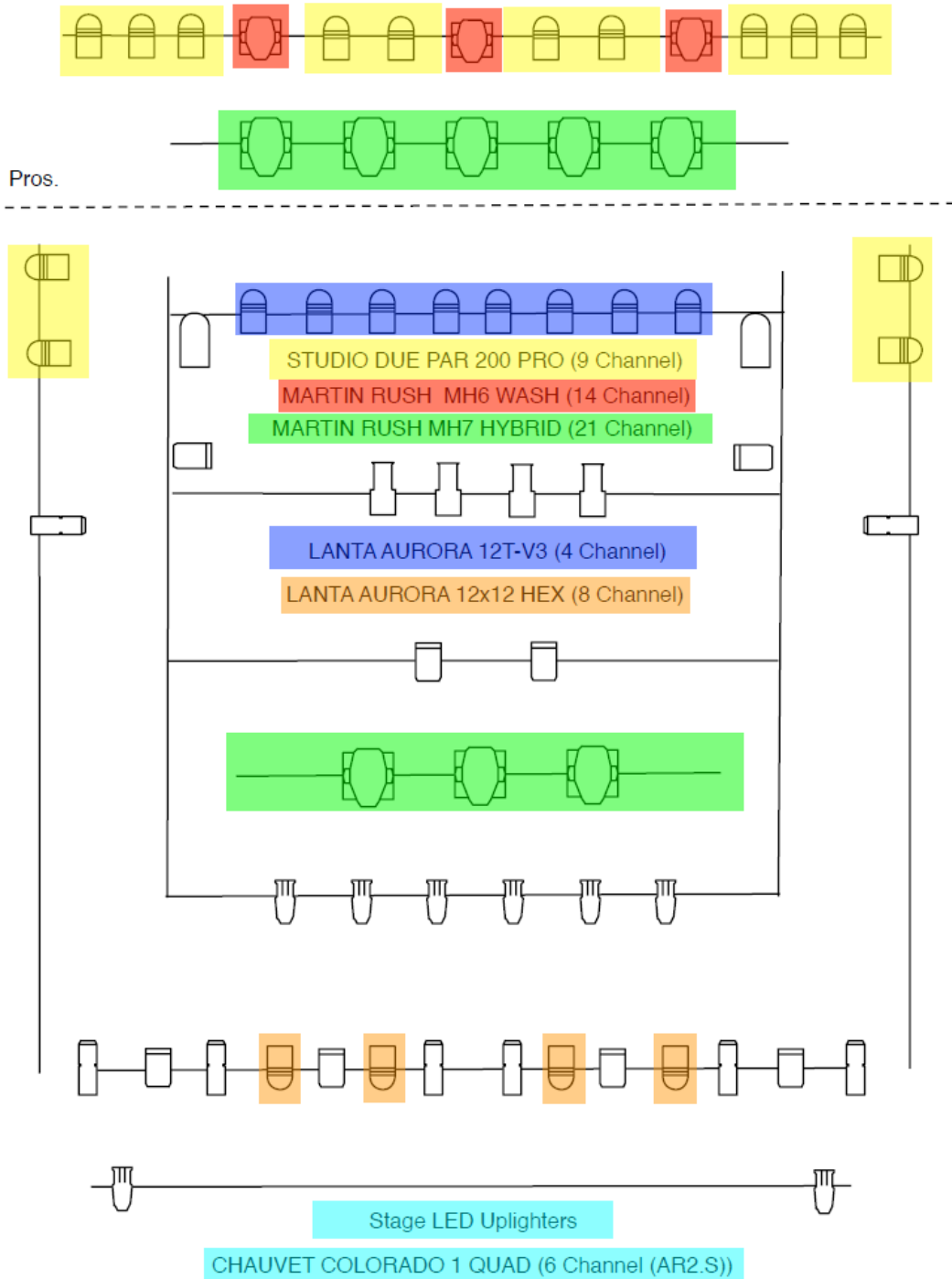

For further information please contact The Stables Technical Department
on 01908 280822 or email technical@stables.org

Non-Generic Lighting Fixtures Plot

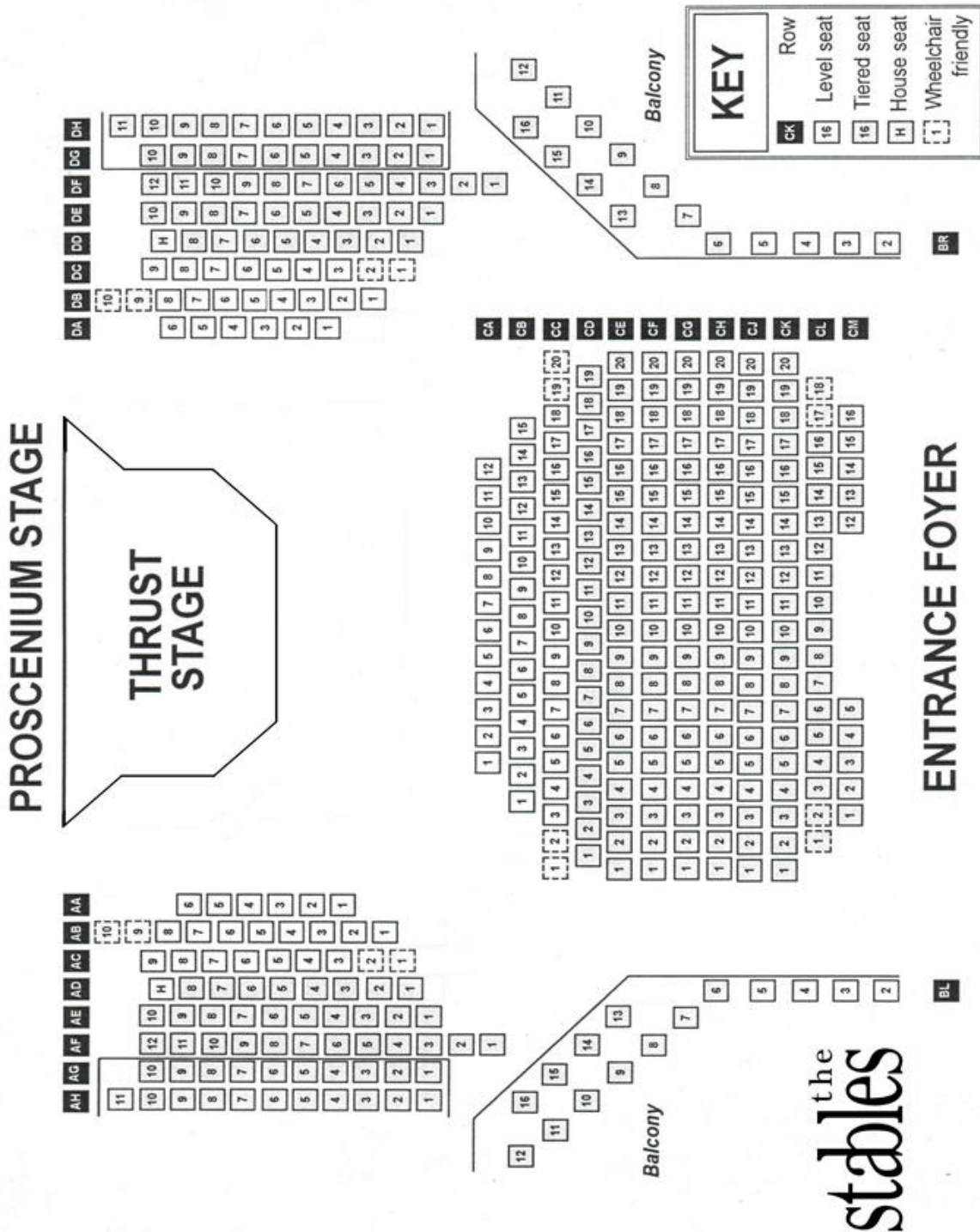

For further information please contact The Stables Technical Department on 01908 280822 or email technical@stables.org

JMA Rig – Onstage

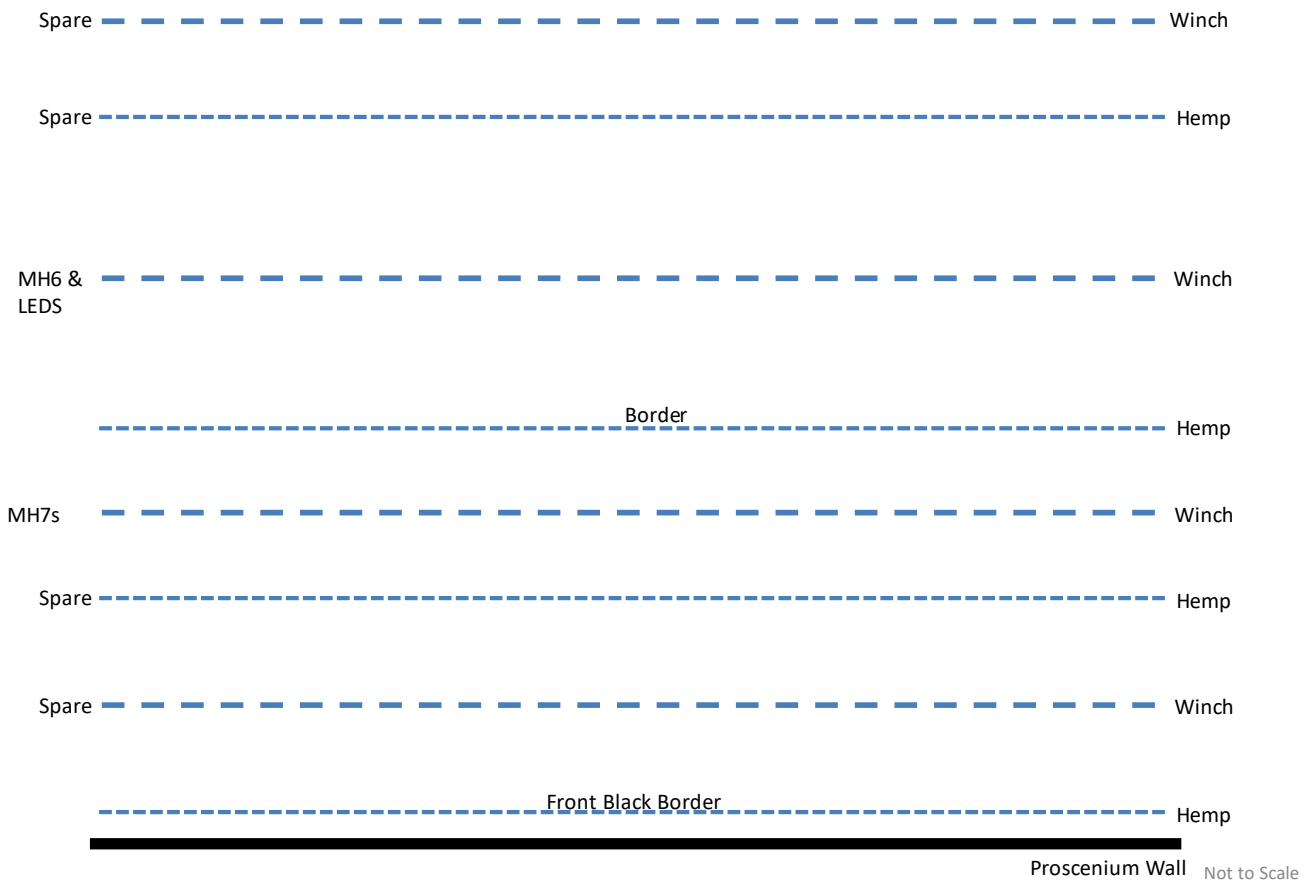

For further information please contact The Stables Technical Department
on 01908 280822 or email technical@stables.org

JMA Thrust Stage Layout and Measurements

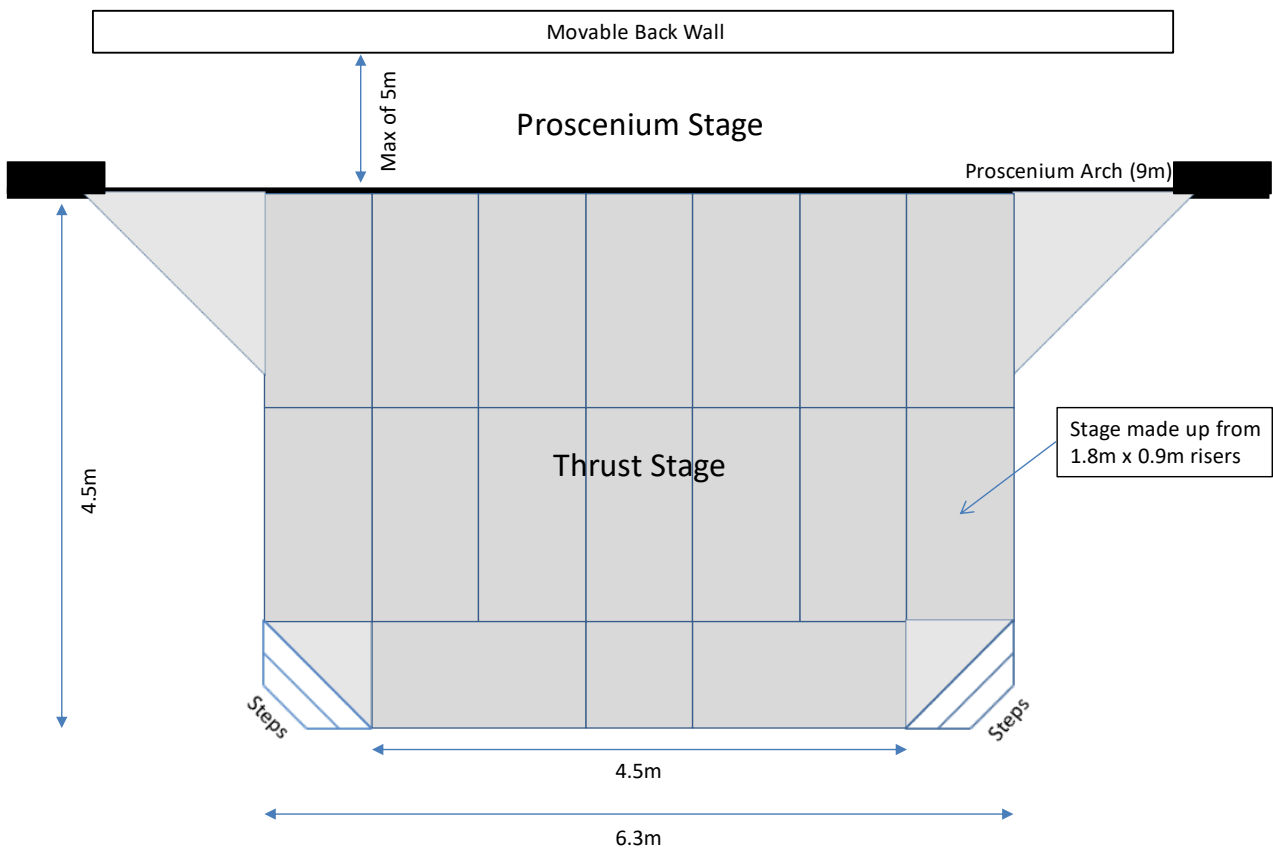

For further information please contact The Stables Technical Department
on 01908 280822 or email technical@stables.org

Stage and Auditorium Visual

Jim Marshall Auditorium

Main House:

Full Capacity: 398 (including 8 disabled allocation),
(244 straight on, 144 on side blocks)

Dimensions:

Jim Marshall Auditorium: Proscenium stage with no rake, prompt corner S/L
Proscenium opening 9m/29ft, height 4.6m/15ft, depth without thrust 4m/13ft
with thrust 7.5m/24.5ft. Thrust narrows to 4.2m/13.5ft after extending 2.1m/6.9ft
Height to Grid 6.5m/21.3ft. Height to underside of towers 4m/13ft
Masking: U/S Blacks and 4 flats (2m/6ft x 5m/16.5ft)

